

ABCs of Fryer Preventive Maintenance

A: Filtration

- Remove the filter pan from the fryer and clean thoroughly.
- Remove all water from the components.

- Reassemble carefully. The bottom screen goes in first.



Place the inner screen in first (above) and then the

- Lay the filter paper in the pan, ensuring it rests against the wall.



- Place the hold-down ring in the pan, ensuring a couple of inches of paper is trapped against the wall of the filter pan.

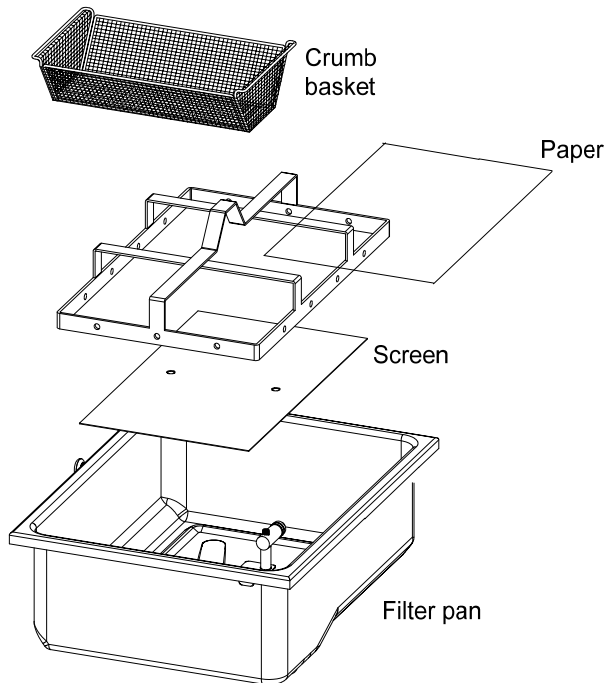

***NOTE:** The contents of the crumb tray should be dumped into a fireproof container daily.

- Add 8 ounces of filter powder.
- Return the cleaned crumb tray.
- Slide the filter pan into place under the lid.
- Heat the oil to operating temperature; turn the fryer off. Open the drain valve on one frypot.

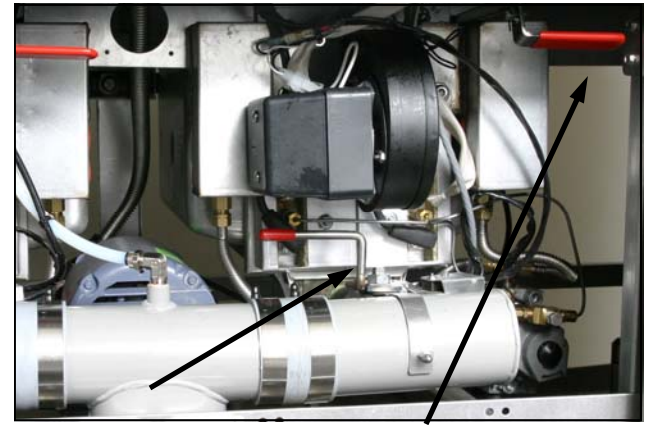

Drain valve Filter lever

- The oil drains from the frypot. Leave the drain valve open.
- Pull the filter handle.
- Allow the oil to flow for five minutes.
- Close the drain valve. Leave the filter pump on. The frypot fills.
- Allow the oil to bubble for 10 to 15 seconds to clear the oil return lines. Turn the filter pump off.
- Turn the fryer on and allow it to heat to operating temperature. Add more oil if necessary to raise the level to the upper etched line in the frypot.

B: Boilout

- Drain and dispose of the old oil.
- Close the drain valve and fill the vat to the lower fill line with water and cleaner mixture.
- Turn the fryer on. Press the checkmark key on the computer. CODE appears. Enter 1653 with the product keys. Boil is displayed on the computer.
- On analog-controlled fryers, set the temperature to between 190-212°F.
- Scrub the fryer with a long-handled

brush to remove stubborn stains.



Add cleaning solution to water in the frypot.

- Allow the solution to simmer for 1 hour.
- Drain the solution into a metal stockpot. Do not drain into the filter system or an SDU. **Do not use** a plastic or glass bucket to drain the solution.
- Rinse the frypot with fresh water and dry completely.
- Refill the frypot with fresh oil to the lower etched line on the frypot.



Scrub stubborn stains with a brush as the cleaning solution simmers in the frypot.



Drain slowly into a metal stockpot. Do not drain into the filter system or an SDU.

C: Cleaning Blower

High-efficiency gas units only

- Remove the blower motor and housing from the fryer.
- Remove the housing from the motor.
- Cover the motor with a plastic bag.
- Spray housing and blower wheel with degreaser.
- Rinse, removing oil, dirt and



Remove the four bolts that hold the blower motor (above) to the fryer and disconnect the electrical connection. Clean the housing and wheel (right) while protecting the motor from moisture.

- Dry the blower assembly compo-

CAUTION
Wear protective clothing and use caution in all operations. Hot solutions can cause serious injuries.



nents and reassemble and reinstall on the fryer. Repeat for all blower motors.